

TRICEL (KILLARNEY) UNLIMITED COMPANY RESERVES THE RIGHT TO CHANGE THE SPECIFICATION WITHOUT PRIOR NOTIFICATION.

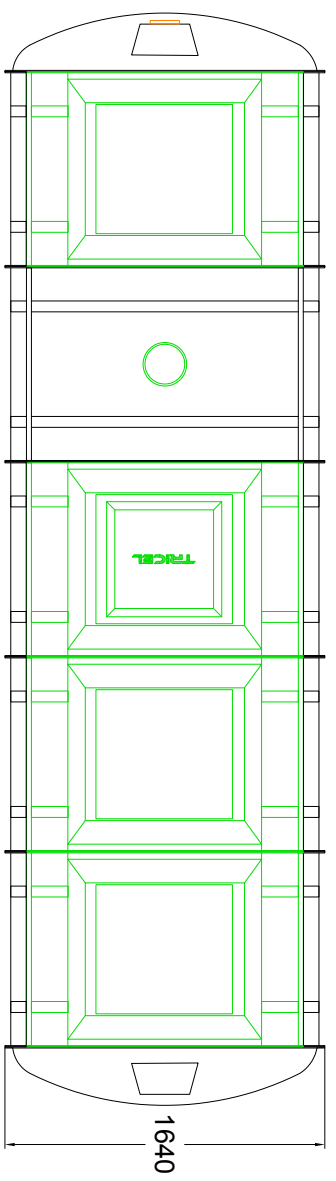

DRAWN BY		DRAWING DATE (DD/MM/YY)		EFFECTIVE DATE: (DD/MM/YY)		PRODUCT NAME:		PRODUCT NUMBER:		ACC NUMBER:	
NR		30/05/17		30/05/17		Novo UK24 Gravity		TGUK2401		N/A	
TOLERANCE: +/-5			MATERIAL: GRP			SCALE: NOT TO SCALE			DRAWING TYPE: SALES		
UNITS: mm			DRWG NO: N/A			TANK REVISION: AE			REV. NO. 00		
JOB NUMBER: N/A			WEIGHT (KG): 600KG			PROJECT NO: 239			ECO NO: 59		
6			5			4			3		
A			B			C			D		
A			B			C			D		

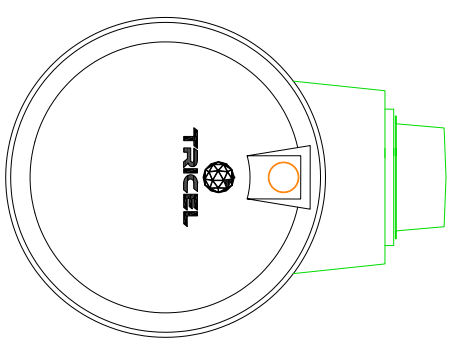
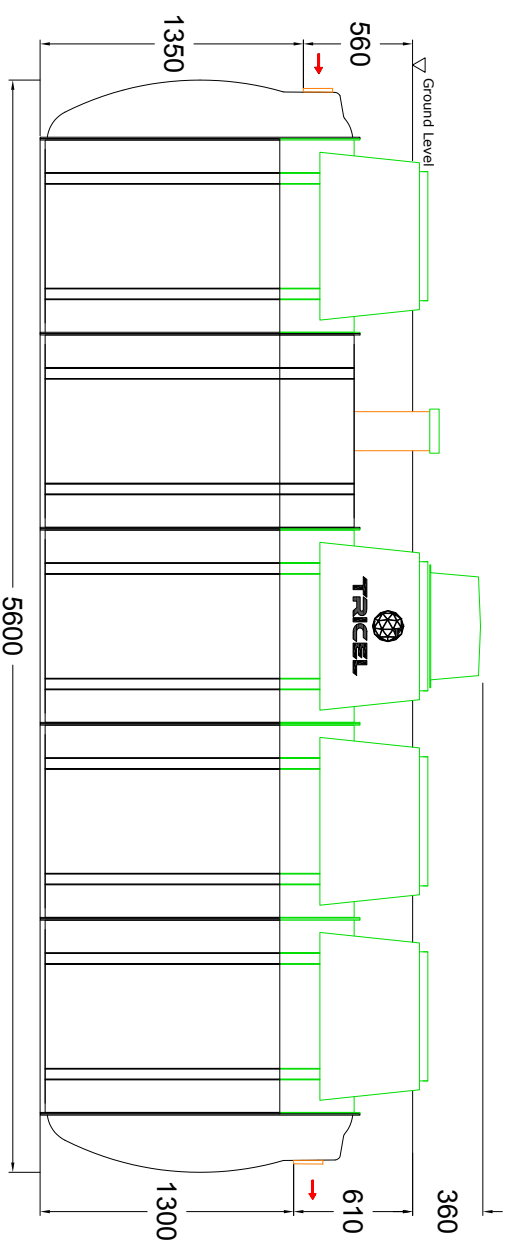

TRICEL

PRINTED COPIES OF THIS DOCUMENT ARE UNCONTROLLED UNLESS STATED OTHERWISE.